

Superroll Inquiry Sheet

Contact us

Sugino Machine France S.A.S.

E-mail: contact@sugino.eu

● Contact information (Fields with * are required.)

* Name	
* Company Name	
Division	
* Company Address	

Requested response due date:

* Phone	
Fax	
E-mail Address	

● Fill in the following contents.

Workpiece name						
Workpiece material						
Workpiece hardness	(HRC, HV, HB, Others)					
Workpiece form (Circle one.)	①	②	③	④	⑤	⑥
Diameter $\phi D1$	ϕ	Tolerance				
Diameter $\phi D2$	ϕ	Tolerance				
Length L						Tolerance
Interference height H						Tolerance
Corner R						
Angle θ°	degree	Tolerance				
Required shank form						
Tool length limitation (shank length not included)						
Driving unit in use						
Purpose of use (Circle one or more.)	<ul style="list-style-type: none"> • Improvement of surface roughness • Hardness improvement • Dimensional correction • Others 					

Work configuration

Special tools for work configurations not shown below can be produced.

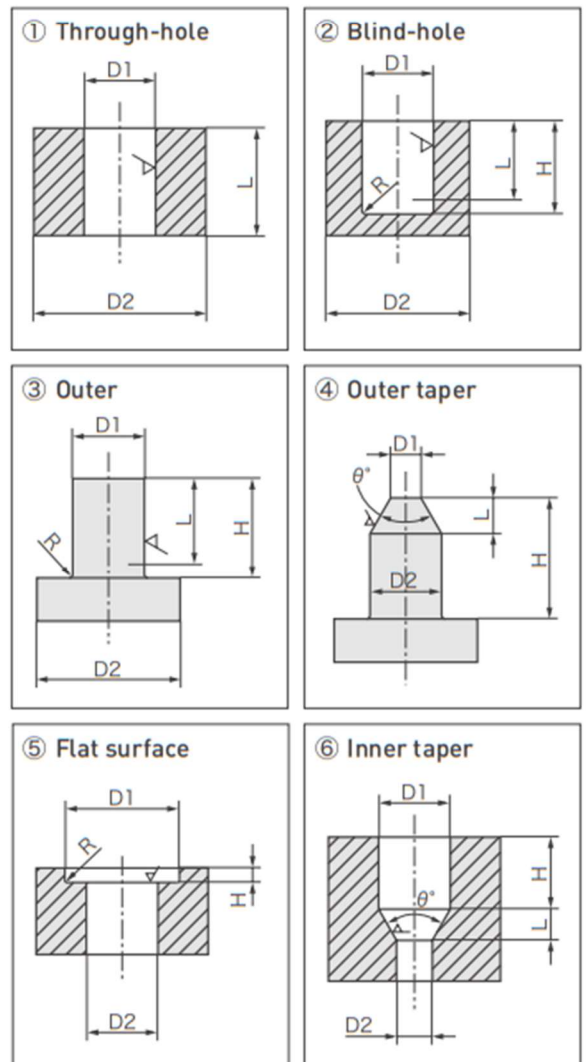

● Clarify the unit. (e.g., μm , mm, Rz, HRC, HV, HB)

Surface roughness	Before burnishing	After burnishing
Hardness improvement	Before burnishing	After burnishing
Dimensional correction	Before burnishing	After burnishing
Other accuracy	Before burnishing	After burnishing
Work piece drawing (Please attach a drawing of the work in order to check interference between the tool and the work.)	Attached / Not attached	

Remarks

Visit by our salesperson (Check here if requesting.)